

**BALDOR® • RELIANCE** 

**Product Information Packet**

**AEM2238-4**

**10HP, 1765RPM, 3PH, 60HZ, 256U, 0932M, TEFC, F1**

Part Detail							
Revision:	G	Status:	PRD/A	Change #:		Proprietary:	No
Type:	AC	Elec. Spec:	09WGZ993	CD Diagram:	CD0006	Mfg Plant:	
Mech. Spec:	09T36	Layout:	09LYT036	Poles:	04	Created Date:	02-21-2015
Base:	RG	Eff. Date:	01-26-2017	Leads:	3#12		

Specs			
Catalog Number:	AEM2238-4	Inverter Code:	Inverter Ready
Enclosure:	TEFC	KVA Code:	H
Frame:	256U	Lifting Lugs:	Standard Lifting Lugs
Frame Material:	Iron	Locked Bearing Indicator:	Locked Bearing
Output @ Frequency:	10.000 HP @ 60 HZ	Motor Lead Quantity/Wire Size:	3 @ 12 AWG
Synchronous Speed @ Frequency:	1800 RPM @ 60 HZ	Motor Lead Exit:	Ko Box
Voltage @ Frequency:	460.0 V @ 60 HZ	Motor Lead Termination:	Ring Terminals
XP Class and Group:	None	Motor Type:	0932M
XP Division:	Not Applicable	Mounting Arrangement:	F1
Agency Approvals:	UR	Power Factor:	82
	CSA	Product Family:	Automotive (Not For DC)
Auxillary Box:	No Auxillary Box	Pulley End Bearing Type:	Ball
Auxillary Box Lead Termination:	None	Pulley Face Code:	Standard
Base Indicator:	Rigid	Pulley Shaft Indicator:	Standard
Bearing Grease Type:	Polyrex EM (-20F +300F)	Rodent Screen:	None
Blower:	None	Shaft Extension Location:	Pulley End
Current @ Voltage:	12.200 A @ 460.0 V	Shaft Ground Indicator:	No Shaft Grounding
Design Code:	B	Shaft Rotation:	Reversible

<b>Drip Cover:</b>	No Drip Cover	<b>Shaft Slinger Indicator:</b>	Shaft Slinger
<b>Duty Rating:</b>	CONT	<b>Speed Code:</b>	Single Speed
<b>Electrically Isolated Bearing:</b>	Not Electrically Isolated	<b>Motor Standards:</b>	NEMA
<b>Feedback Device:</b>	NO FEEDBACK	<b>Starting Method:</b>	Direct on line
<b>Front Face Code:</b>	Standard	<b>Thermal Device - Bearing:</b>	NONE (OLD)
<b>Front Shaft Indicator:</b>	None	<b>Thermal Device - Winding:</b>	None
<b>Heater Indicator:</b>	No Heater	<b>Vibration Sensor Indicator:</b>	No Vibration Sensor
<b>Insulation Class:</b>	F	<b>Winding Thermal 1:</b>	None
		<b>Winding Thermal 2:</b>	None

Nameplate NP1404E	
CAT.NO.	AEM2238-4
SPEC.	09T036Z993G1
VOLTS	460
AMP	12.2
RPM	1765
	HP 10
FRAME	256U
	HZ 60
	PH 3
SER.F.	1.00
	CODE H
	DES B
	CL F
NEMA-NOM-EFF	91.7
	PF 82
G.MIN.EFF	90.2
	CC 010A
RATING	65C AMB-CONT
LUBRICATION	POLYREX EM
DE	6309
	ODE 6208
ENCL	TEFC
	SER. #

Parts List		
Part Number	Description	Quantity
SA294164	SA 09T036Z993G1	1.000 EA
RA280246	RA 09T036Z993G1	1.000 EA
09FN3001D01SP	EXTERNAL FAN, PLASTIC	1.000 EA
HW1002A63	WASHER, 5/8 HI-COLLAR SPRLOCKWASHER	1.000 EA
09CB1002A12P	KOBY W/1.25 NPT LEAD HOLE & 2.38 MTG HOL	1.000 EA
09GS1010	GASKET, DWG, LEADWIRE SEPERATOR	1.000 EA
10XN2520K12	1/4-20 X.75 GRD 5	4.000 EA
HW1001A25	LOCKWASHER 1/4, ZINC PLT .493 OD, .255 I	4.000 EA
09EP1100A14P	ENDPLATE, MACH W/EPOXY PRIMER	1.000 EA
HA3400A33	STUD- 3/8-16 X 4.82 HEX WELKER	4.000 EA
WD1000B16	T&B CX70TN TERMINAL	1.000 EA
10XN2520K06	1/4-20 X 3/8" HX HD SCREWGRADE 5, ZINC P	1.000 EA
HW1001A25	LOCKWASHER 1/4, ZINC PLT .493 OD, .255 I	1.000 EA
HW1001A38	LOCKWASHER 3/8, ZINC PLT .688 OD, .382 I	4.000 EA
HW4600B44	V-RING SLINGER 1.500 X 1.810 X .28 VITON	1.000 EA
12CB1500A01P	CONDUIT BOX LID, MACH W/EPOXY PRIMER	1.000 EA
12GS1002	GASKET, CONDUIT BOX LID, NEOP	1.000 EA
10XN3118K24	5/16-18 X 1.50" HEX HD, GRADE 5	2.000 EA
HW1001A31	LOCKWASHER 5/16, ZINC PLT.591 OD, .319 I	2.000 EA
HA1005A12	SLINGER, OD 2.50, ID 1.433, 208 BRG	1.000 EA
HW5100A08	W3118-035 WVY WSHR (WB)	1.000 EA
10XN2520K28	1/4-20 X 1.75" HX HD SCRWGRADE 5, ZINC P	2.000 EA
09EP1101A11P	MACH'D EPOXY PRIMED EP	1.000 EA
10XN3816K24	3/8-16 X 1.50 HEX HD CAP SCREW, GRADE 5	4.000 EA

Parts List (continued)		
Part Number	Description	Quantity
HW1001A38	LOCKWASHER 3/8, ZINC PLT .688 OD, .382 I	4.000 EA
10XN2520K36	1/4-20 X 2.25" HX HD SCRWGRADE 5, ZINC P	4.000 EA
09FH4000P	FAN COVER, STAMPED W/EPOXY PRIMER	1.000 EA
XY3816A12	3/8-16 FINISHED NUT	4.000 EA
HW1001A38	LOCKWASHER 3/8, ZINC PLT .688 OD, .382 I	4.000 EA
HW2501F24	KEY, 5/16 SQ X 2.750	1.000 EA
MJ5001A27	32220KN GRAY SEALER *MIN BUY 4 QTS=1GAL	0.031 QT
MJ5002A01	SILICON RUBBER SEALANT, 732CL 10.3 OZ TU	0.050 EA
MJ5001A14	DYNAPRO SEALANT, CP MTR VC#2508050 (603	0.001 EA
MJ5004A04	ADHESIVE LOCTITE 609	0.005 EA
LB1115N	LABEL,LIFTING DEVICE (ON ROLLS)	1.000 EA
WD1000B07	T&B C71, RING TERM 10-12 AWG, .25" STUD	3.000 EA
HW4500A20	1/8NPT SL PIPE PLUG	2.000 EA
HA4054	SHORT T-DRAIN FITTING, .125" N.P.T.	1.000 EA
MJ1000A02	GREASE, POLYREX EM EXXON (USe 4824-15A)	0.080 LB
HW4500A20	1/8NPT SL PIPE PLUG	3.000 EA
HW2500A25	WOODRUFF KEY USA #1008 #BLOW CARBON STEE	1.000 EA
51XB1214A20	12-14X1.25 HXWSSLD SERTYB	1.000 EA
MG1025G02	WILKOFASST, 782.02, LIGHT GRAY	0.050 GA
85XU0407S04	4X1/4 U DRIVE PIN STAINLESS	2.000 EA
LB1119N	WARNING LABEL	1.000 EA
LC0006	CONNECTION LABEL	1.000 EA
NP1404E	SS UL CSA CC "AUTOMOTIVE"	1.000 EA
09PA1000	PACKAGING GROUP COMBINED PRINT	1.000 EA

MN416A01	TAG-INSTAL-MAINT no wire (1200/bx) 5/18	1.000 EA
----------	---	----------

<b>Accessories</b>		
<b>Part Number</b>	<b>Description</b>	<b>Multiplier</b>
09-1309	C FACE KIT	A8



**AC Induction Motor Performance Data**

Record # 49356 - Typical performance - not guaranteed values

<b>Winding:</b> 09WGZ993-R003	<b>Type:</b> 0932M	<b>Enclosure:</b> TEFC
-------------------------------	--------------------	------------------------

Nameplate Data				460 V, 60 Hz: Single Voltage Motor	
Rated Output (HP)	10			Full Load Torque	29.5 LB-FT
Volts	460			Start Configuration	direct on line
Full Load Amps	12.2			Breakdown Torque	99.2 LB-FT
R.P.M.	1765			Pull-up Torque	40.6 LB-FT
Hz	60	Phase	3	Locked-rotor Torque	51.3 LB-FT
NEMA Design Code	B	KVA Code	H	Starting Current	79.1 A
Service Factor (S.F.)	1			No-load Current	4.9 A
NEMA Nom. Eff.	91.7	Power Factor	82	Line-line Res. @ 25°C	1.02 Ω
Rating - Duty	65C AMB-CONT			Temp. Rise @ Rated Load	33°C
				Locked-rotor Power Factor	36
				Rotor inertia	1.4 LB-FT <sup>2</sup>

Load Characteristics 460 V, 60 Hz, 10 HP

% of Rated Load	25	50	75	100	125	150
Power Factor	47	70	80	83	85	86
Efficiency	85.8	90.8	92	91.7	91	89.9
Speed	1793	1786	1778	1770	1760	1750
Line amperes	5.62	7.27	9.5	12.2	15	18

Performance Graph at 460V, 60Hz, 10.0HP Typical performance - Not guaranteed values

**BALDOR ELECTRIC COMPANY**

WINDING # 09WGZ993

Typical performance - not guaranteed values.

10 HP 3 PH 60 HZ 1765 RPM 460 V 0932M

TORQUES(LB-FT): PO=99.2 PU=40.6 LR=51.3 LRA=79.1

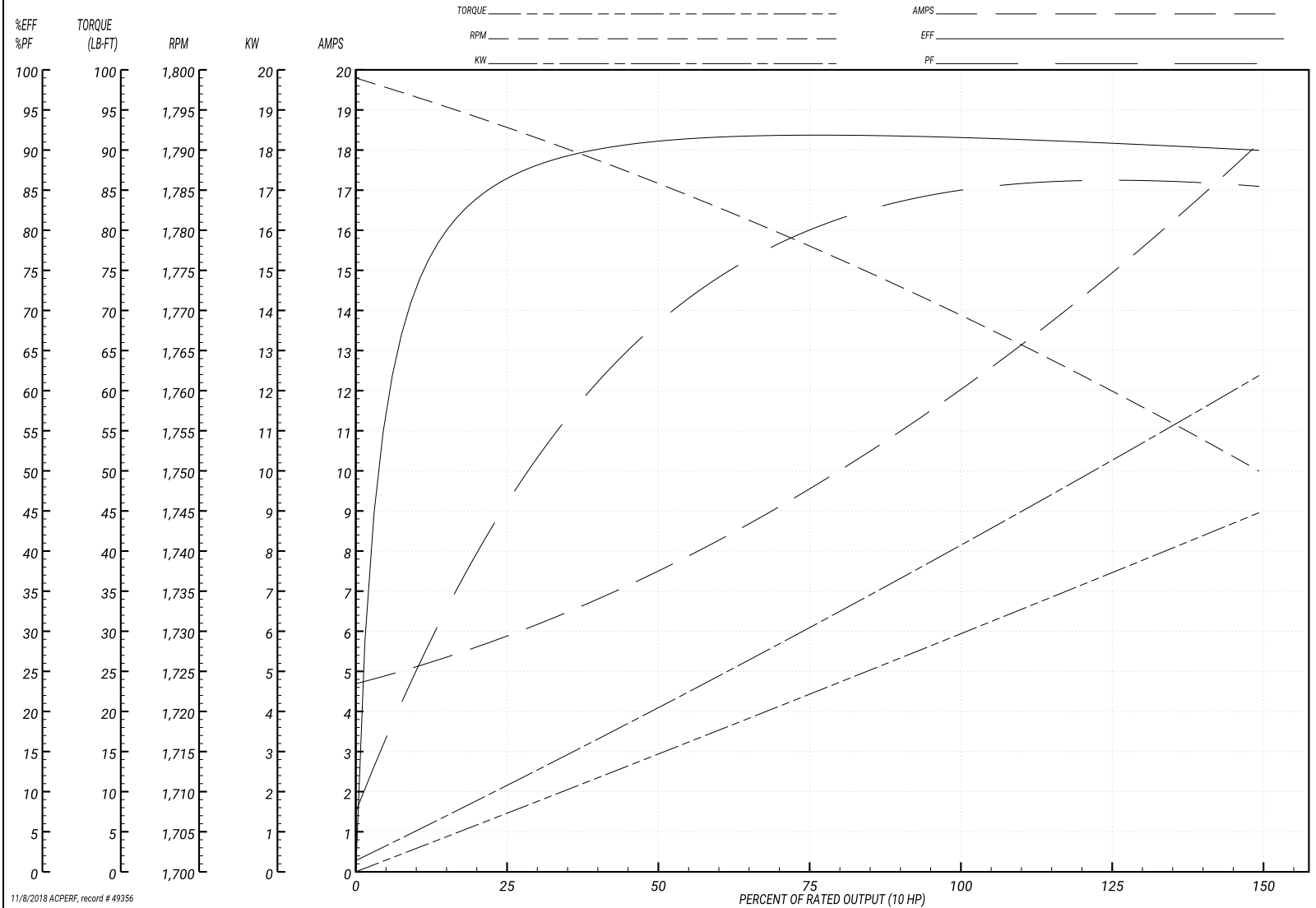

11/8/2018 ACPERF, record # 49356

09LYT036

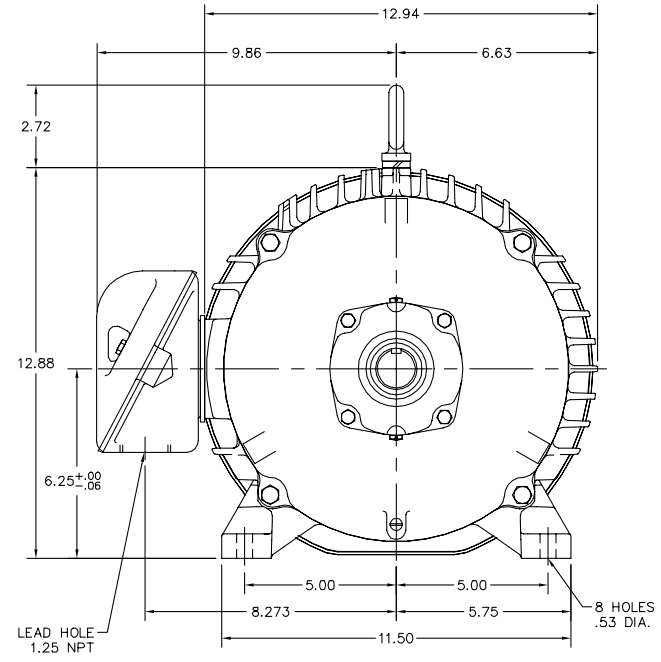
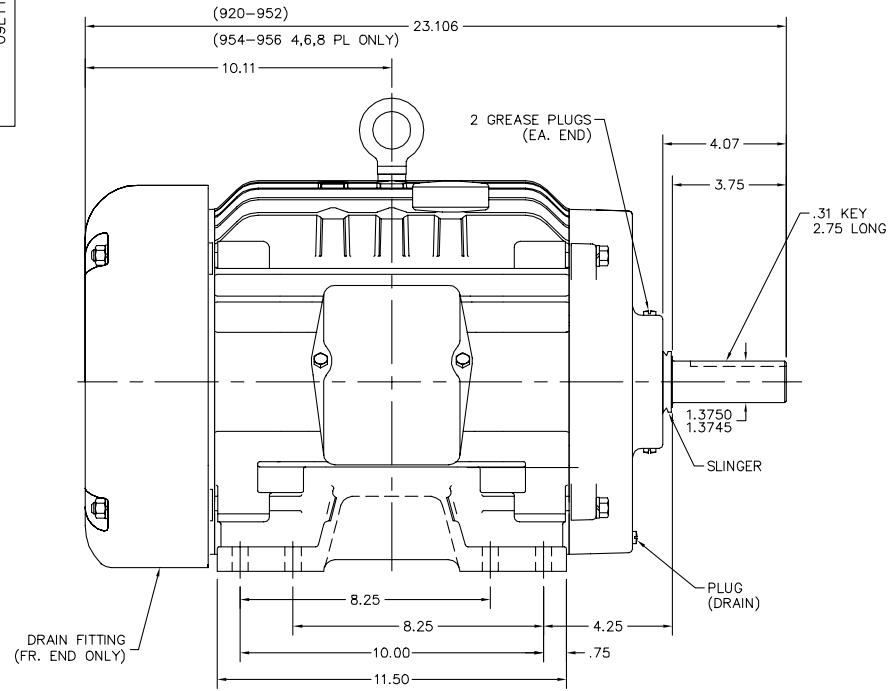

09LYT036

CUSTOMER IS RESPONSIBLE FOR DETERMINING THAT BALDOR'S PRODUCT WILL PERFORM SUITABLY IN THE INTENDED APPLICATION. GM SPECS

REV. DESC: REVISED TO ADD DRAIN FITTING LEADER TO FRONT END	TDR: 000001012375
REV. LTR: L	VERSION: 04
FILE: \AAA\00007\874	REVISED: 07:18:46 01/20/2017
MTL: -	BY: USSADEL11

**BALDOR**  
 HORZ TEFC 254-6U (GM SPECS)  
 SH 1 of 1

CD0006

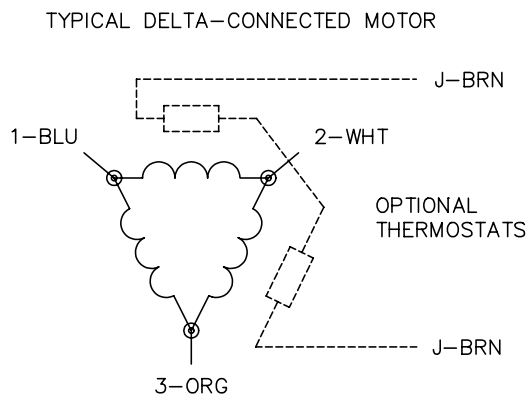
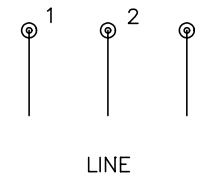
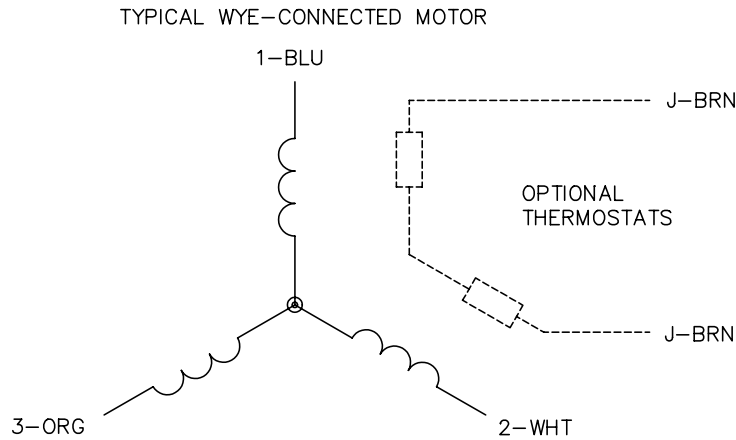

NOTES:

1. THREE LEAD MOTOR MAY BE EITHER WYE CONNECTED OR DELTA CONNECTED.
2. INTERCHANGE ANY TWO LINE LEADS TO REVERSE ROTATION.
3. OPTIONAL THERMOSTATS ARE PROVIDED WHEN SPECIFIED.
4. ACTUAL NUMBER OF INTERNAL PARALLEL CIRCUITS MAY VARY.
5. LEAD COLORS ARE OPTIONAL. LEADS MUST BE NUMBERED AS SHOWN.

REV. DESC: REVISE TO SHOW OPTIONAL COLORS			
REV. LTR: D	BY: JLP	REVISED: 01/21/99 4:02	TDR: 0171435
9000D		FILE: AAA00005141	MDL: -
		MTL: -	

**BALDOR ELECTRIC Co.**

3PH, SV, 3 LEADS, WYE OR DELTA CONNECTED

CD0006

Marketing maintained PDF of MN416:

<http://www.baldor.com/support/Literature/Load.ashx/MN416?ManNumber=MN416>